

### GENERAL

Unpack shaft replacement kit and compare contents with the parts list below. Verify kit received is the correct rotation for your operation, kit is for pump with **counter-clockwise** rotation, shaft should have **left hand** threads.

#### California Proposition 65 Warning

**▲WARNING** This product and related accessories contain chemicals known to the State of California to cause cancer, birth defects or other reproductive harm.

### PARTS LIST

Ref. No.	Part Description	Qty.	B2-1/2ZR B3ZR B6ZR CCW Packing B80695	B2-1/2ZR B3ZR B6ZR CCW Packing B80696	B2-1/2ZR B3ZR B6ZR CCW Seal B80697
1	Hex Locknut 7/8-89 S.S.	1	-	U36-189SS	U36-189SS
2	Retaining Ring	1	-	-	S23009
3	Shaft Sleeve	1	S05127	S05127	S39242
4	Bearing	1	S13270	S13270	S13270
5	Shaft	1	M12402	M12398	M12398
6	Key	1	S24255	S24255	S24255
7	Bearing	1	S13271	S13271	S13271
8	Thrust Ring	1	S29218	S29218	S29218
9	Retaining Ring	1	S23010	S23010	S23010

**NOTE:** Model B6ZRM does not require locknut.

\* Does not include heavy duty Z frame series.

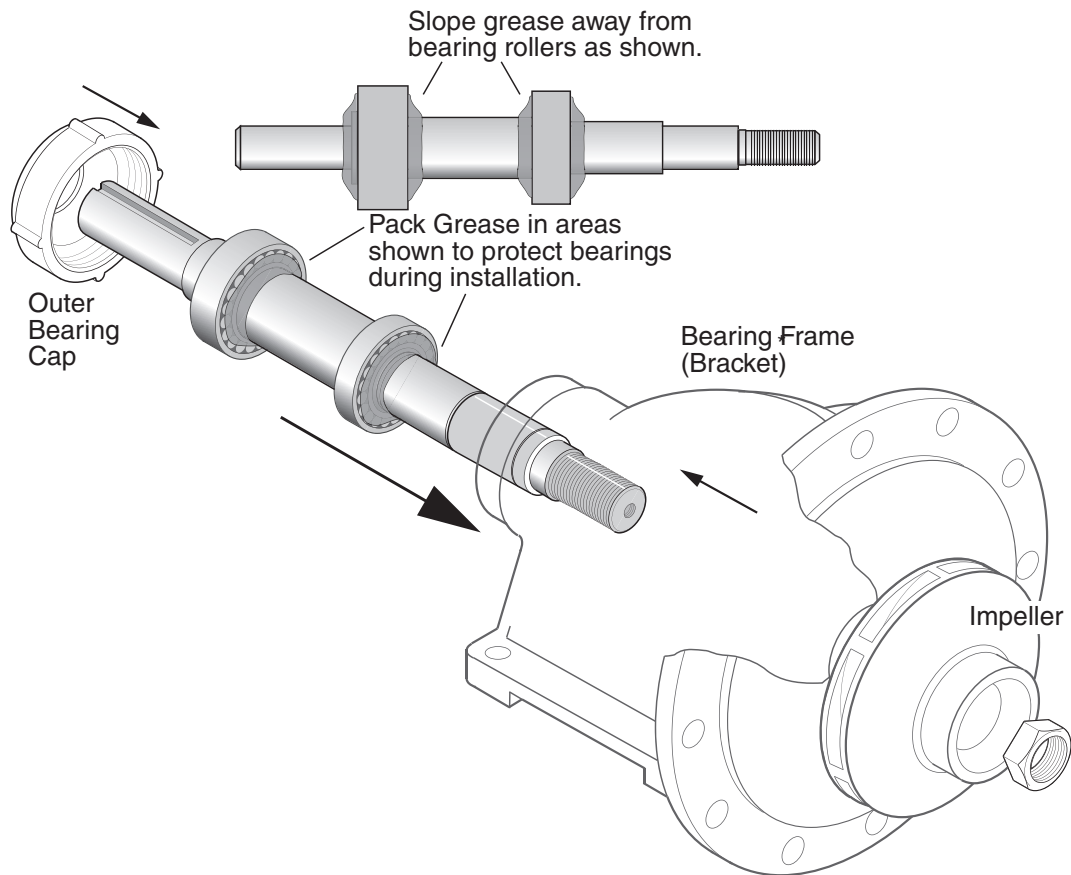

## INSTALLATION

1. Thoroughly steam clean or solvent wash the bearing cavity of bearing bracket to remove old grease and dirt. Check surface of bracket for cracks, extreme corrosion, or other defects that may make replacement of the bracket necessary.
2. Pack bearings with a lithium based NGLI No. 2 extra pressure ball bearing grease. Force enough grease into each bearing to fill internal space between the races.
3. Coat the bearing bores of bracket with oil. Orient shaft kit in the direction shown above. Protect the bearings from contamination during installation by applying grease around bearings as shown. Slide shaft and bearing assembly into bearing bracket. When threaded end of pump shaft comes through inner bearing cap, place slinger and lantern ring over end of shaft. If packing gland is not of the split variety, place it over the shaft at this time as well. Slide shaft on through stuffing box until the first bearing makes contact with the bracket. Carefully align bearing with the bearing bore and press or tap bearing assembly into place. **Do not use excessive force.**
4. Screw outer bearing cap tightly against outer bearing race of double row bearing.
5. Inject grease into grease fittings to fill cavities behind bearings.
6. Reassemble pump parts and install unit. Refer to pump owners manual for correct installation procedures.