

GENERAL

Unpack shaft replacement kit and compare contents with the parts list below. Verify that the kit received is the correct rotation for your operation. Kit is for pump with **clockwise** rotation (viewed from the motor end of the shaft; the shaft should have **right hand** threads).

California Proposition 65 Warning

▲ WARNING This product and related accessories contain chemicals known to the State of California to cause cancer, birth defects or other reproductive harm.

PARTS LIST

Key No.	Part Description	Qty.	Shaft Kit No.		
			B82183	B82184	B85571
1	Shaft Sleeve	1	S05127L	S05127L	-
2	Retaining Ring	1	-	-	S23009
3	Shaft Sleeve with Retaining Ring Groove	1	-	-	S39242L
4	Bearing	1	S13270	S13270	S13270
5	Shaft	1	M12404	M12403	M12403
6	Shaft Key	1	S24255	S24255	S24255
7	Bearing	1	S13269	S13271	S13271
8	Thrust Ring	1	S29218	S29218	S29218
9	Retaining Ring	1	S23010	S23010	S23010

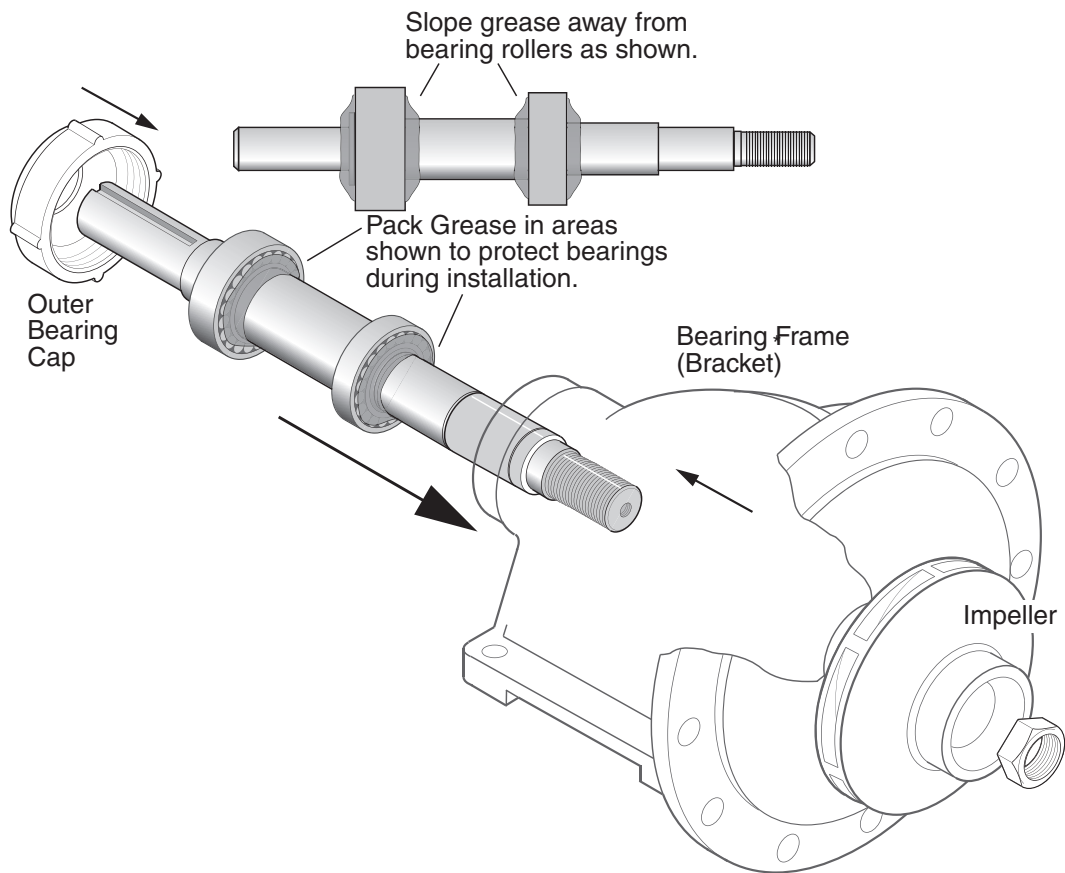

INSTALLATION

1. Thoroughly steam clean or solvent wash the bearing cavity of bearing bracket to remove old grease and dirt. Check surface of bracket for cracks, extreme corrosion, or other defects that may make replacement of the bracket necessary.
2. Pack bearings with a lithium based NGLI No. 2 extra pressure ball bearing grease. Force enough grease into each bearing to fill internal space between the races.
3. Coat the bearing bores of bracket with oil. Orient shaft kit in the direction shown above. Protect the bearings from contamination during installation by applying grease around bearings as shown. Slide shaft and bearing assembly into bearing bracket. When threaded end of pump shaft comes through inner bearing cap, place slinger over end of shaft. If packing gland is not of the split variety, place it over the shaft at this time as well. Slide shaft on through stuffing box until the first bearing makes contact with the bracket. Carefully align bearing with the bearing bore and press or tap bearing assembly into place. **Do not use excessive force.**
4. Screw outer bearing cap tightly against outer bearing race of double row bearing.
5. Inject grease into grease fittings to fill cavities behind bearings.
6. Reassemble pump parts and install unit. Refer to pump owners manual for correct installation procedures.